

## KD12 & KD30 Series Float Level Switches

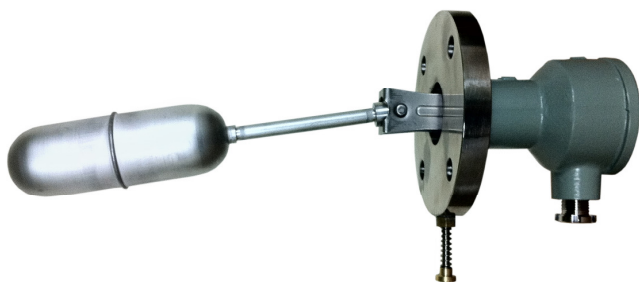

### Key features

- Horizontal or vertical mounting
- Rugged construction suitable for harsh marine environments
- Reliable and maintenance free
- Marine Type approved
- Single and multipoint switching
- Optional manual test mechanism



## **KD Series Mechanical Marine Float Level Switch**

Marine float level switches, from PSM, whether horizontally or vertically mounted, provide high-level or low-level detection of liquids in all types of vessels.

PSM offers a wide range of float switch models that will suit each specific application, with single or dual levels switches and multiple combinations of high and low level functions.

### **Horizontal or Vertical Mounting**

The KD12 switch is mounted horizontally in the tank wall, and uses a cylindrical float with a magnet attached to the end of the lever arm that activates a reed type magnetic micro-switch in the electrical connection housing as the float rises or falls.

The KD30 switch is mounted vertically in the tank roof and uses a collar float with an internal magnet that activates a magnetic reed contact internal to the stem of the switch as the float rises or falls. Collars located on the stem limit the travel of the float (or floats on a multipoint switch) and ensure that the float holds the reed switch in the energised position while the alarm condition is present.

For both horizontal and vertical switch types an optional external test handle allows checking of the switch operation from outside the tank irrespective of actual liquid level.

## KD12 Horizontal Mounting Float Level Switch

Model Coding	
KD12	Reed Type Float level Switch
HD	A- Flange (square)
H	JIS 5K 65 A (standard)
HS	S-Shape operating arm
3H	Other flange size (special order)
W	Weatherproof
T	Manual test handle
A	Epoxy coated aluminium housing

Specification	
Max Float Pressure	10 Bar
Max Temp	120°C
Switch Type	Magnetic Float
Contact Rating	250V ac 5A
Cable entry	15b (PF 1/2)
Housing	Epoxy coated aluminium
Float material	304 St. steel
IP rating	IP 56

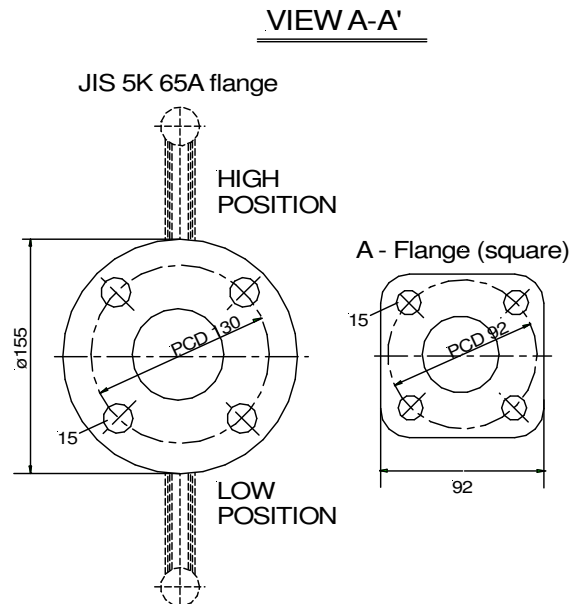
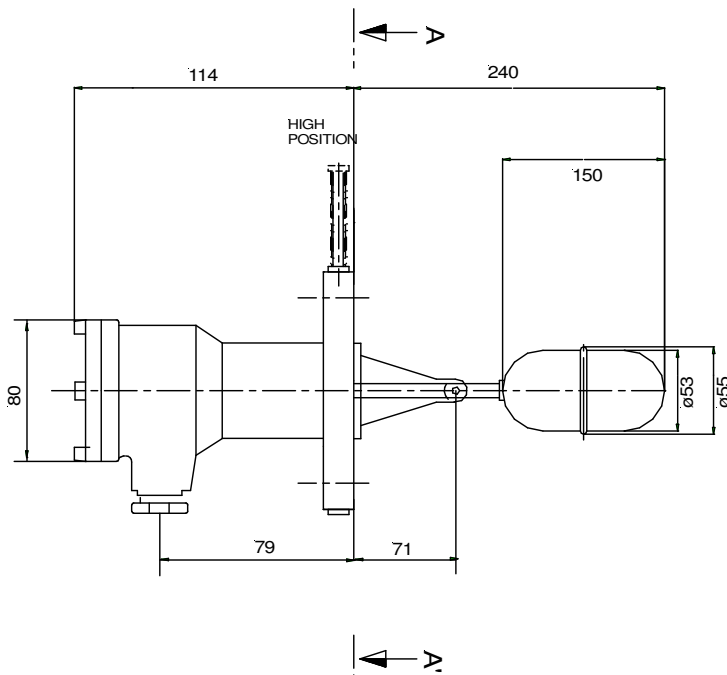

Outline dimensions only. Contact PSM for dimensions depending on housing and float.

## KD30 Vertical Mounting Float Level Switch

Model Coding	
KD30	Reed Type Float level Switch
4M	5K 65A
5M	5K 80 A
6L	5K 100A
7L	10K 80A
8L	10K 100A
9	Non Standard (specify)
10	4" ANSI 150lb
1A	High or Low alarm
2A	High & Low alarm
W	Weatherproof
G	Guide pipe with float
T	Manual test handle
L	Insertion Length mm
L1	1A Switch Point mm**
L2	2A Switch Point mm

Specification	
Max Pressure:	10 Bar
Switch type	SPST Reed Switch
Contact Rating	250 VAC 0.5A
Cable entry	3/4"
Housing:	Epoxy coated aluminium
Flange, Float and Support:	304 St. steel
IP rating	IP 56

\*\*Specify if 1A is High or Low level

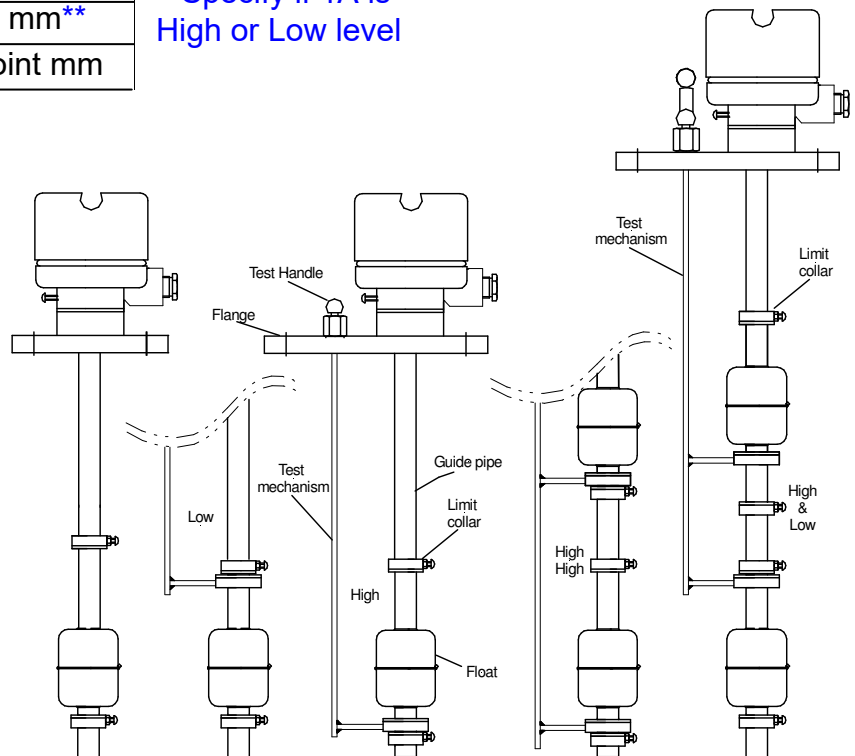
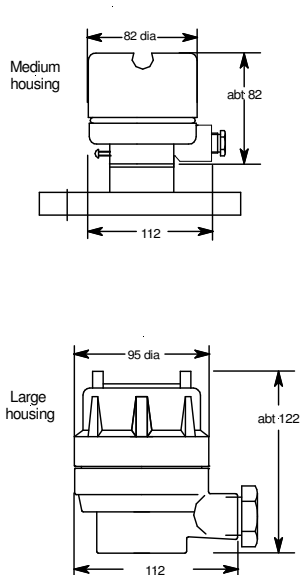

Outline dimensions only. Contact PSM for dimensions depending on housing and float

© PSM INSTRUMENTATION LTD  
Data Sheet Ref: DAT 34R October 2025