



Installation Operation & Maintenance Instruction Manual

APT 500 Series

ATEX & IECEx Versions

Burrell Road Industrial Estate
Haywards Heath, West Sussex RH16 1TW, UK
Tel: +44 (0)1444 410040
www.psmmarine.com E-mail: sales@psmmarine.com

Doc Ref: Man 085K July 2024

Contents

1.	General Information	1
1.1	Safety instructions	1
1.2	Normal operation and maintenance	1
1.3	Product liability and warranty	1
1.4	Product returns	1
1.5	EU conformity	1
2.	Product description	2
2.1	Scope of delivery	2
2.2	Instrument Storage	2
2.3	Instrument Identification	2
2.4	Instrument measurement principle	3
2.5	Instrument calibration	3
3.	Installation	4
3.1	Mechanical installation	4
3.2	Electrical installation	6
4.	Supplement	8
4.1	ATEX and IECEx requirements	8
4.2	Technical Data	11
4.3	Dimensions—submersible version	13
4.4	Dimensions—DIN terminal head version	14
4.5	Dimensions—Stainless Steel terminal head version	15

1. General Information

1.1 Safety instructions

To prevent any damage to the device or any injury to the user it is essential that you read the information in this document and observe applicable national standards and safety requirements.

This document is provided to help facilitate the safe and efficient operation of the instrument.

1.2 Normal operation and maintenance

There is no routine scheduled maintenance requirement for the APT 500. Periodic checks should be made to ensure all wiring/cable glands are in good condition and terminations secure. Where the APT 500 is used in tanks liable to sludge or sedimentation, the sensing diaphragm should be examined at appropriate intervals to ensure it is free from contaminants which may obstruct true reading of pressure.

If cleaning is required, then EXTREME CARE must be taken to avoid damage to the diaphragm. Use a solvent or water to loosen and flush the deposits, and on no account use sharp or hard objects to scrape the diaphragm. If necessary, a soft brush may be used with care.

Damage caused to the diaphragm will result in loss of calibration and likely non-linearity / thermal sensitivity to the instrument.

1.3 Product liability and warranty

All apparatus is carefully examined and tested before leaving the PSM workshop and is sent out in perfect order and condition. We, therefore, give the following Guarantee which takes the place of any Guarantee by Statute, common law or otherwise. If within 12 months from date of dispatch, any defect or fault is discovered in any component of our manufacture, due to faulty material or bad workmanship, we undertake to make good the defect without charge, provided that notice is given to us immediately on the discovery of the defect and the defective components or parts thereof, are forwarded to us carriage paid for inspection. This guarantee does not apply to defects caused by ordinary wear and tear, misuse, neglect, or by circumstances over which we have no control.

Full terms and conditions are available from our website: www.psmmarine.com/about-us

1.4 Product returns

All equipment is carefully examined and tested before leaving the PSM workshop and is sent out in perfect order and condition.

Should it prove necessary to return any equipment for inspection, please ensure you follow the process:

- Contact PSM for an RMA form and number.
- Each instrument must be accompanied by an RMA with clear instructions as to the reason for return and what actions are requested.
- An explanation of the apparent fault together with details of the service conditions are also required.
- Health & Safety requirements mean that we must be fully aware of any potential hazards prior to working on returns.

Full terms and conditions are available from our website: www.psmmarine.com/about-us

1.5 EU conformity

This product meets all of the applicable EU Directives and is supplied with an EU Declaration.

2. Product description

2.1 Scope of delivery

Inspect the packaging and immediately report any signs of damage to your local agent or PSM Instrumentation.



- APT 500 Series - Specific model code will depend on your order specification.
- Installation Operation & Maintenance Instruction Manual.
- EU Declaration.

2.2 Instrument Storage

- Store the instrument in a dry location.
- Storage Temperature range -35°C to $+85^{\circ}\text{C}$.

2.3 Instrument Identification

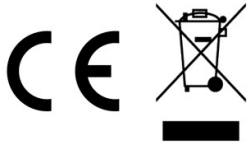
Each instrument is marked with a unique information, that identifies type and construction options.

PSM Instrumentation Ltd (1) Model Code: 550S/I/A/B/1/15/TI (2) S/N: 18089005 (3) Calibrated Range: 0 – 2367 mmWG (4) Cable Length: 15 M (5) Date of Manufacture: 12/02/2018		WWW.psmmarine.com 
Instrument Specification (6) Process Temp: -35°C to $+85^{\circ}\text{C}$ (7) Supply Input: 10 to 30 Vdc (8) Output: 4 – 20mA (9) Material of Construction: Titanium	Specific Information relating to ATEX or IECEx approval (10)	Connection (11) RED: (+) (12) Black: (-) (13) Screen: 

- (1) The model code defines the construction of the sensor. Refer to [4.2 Technical Data](#)
- (2) Unique Serial number consisting of the PSM sales order. For example, 180890, followed by two digits that denote the sensors specific identification from the sales order.
- (3) This is the actual range the sensor has been calibrated too and in what units of measure.
- (4) The specific amount of cable that has been fitted to the sensor.
- (5) The date of when the instrument was factory manufactured.
- (6) The operating temperature of the instrument.
- (7) The range of voltage that can be used for the instrument to operate. **
- (8) The signal that the instrument outputs.
- (9) The specific materials that have been used in the construction of the instrument.
- (10) Will identify the certificate number and any other additional conditions when the Instrument is going to be installed into the hazardous area.
- (11) Red is positive (+) of the 4—20mA loop.
- (12) Black is negative (-) of the 4—20mA loop.
- (13) The screen should be terminated 360° within the cable entry gland to the termination enclosure.
- ** The APT500 is a 2 wire 4-20mA transmitter therefore the maximum load in ohms that can be applied is determined by the available supply voltage based on the following formula

$$\frac{\text{Supply Voltage} - 10}{0.02} = \text{Load in Ohms}$$

Where the supply voltage is insufficient the transmitter will not be able to reach its full scale 20mA output.

2.4 Instrument measurement principle

APT 500 Series level transmitters are designed for monitoring liquid levels and pressures on a wide range of applications. The measurement principle is based on a highly accurate and stable pressure sensitive MEMS piezo-resistive cell.

This pressure measurement cell is isolated from the process by a diaphragm with an internal fluid fill transmitting the process pressure to it. Precise temperature compensation and zero correction are applied during manufacture by laser trimming of compensation resistors.

The output from the measurement cell is converted by an internal circuit to an industry standard 4-20mA signal which is scaled to the user requirements.

The assembled sensor is fully encapsulated internally and a choice of construction materials for the wetted parts of the transmitter provide compatibility with most process fluids.

2.5 Instrument calibration

The APT 500 is a fixed calibration sensor and is factory calibrated to either its nominal range or a specific range as specified by the user specified when ordering.

Absolute sensors

Absolute pressure is measured relative to absolute zero pressure, as would be found in an absolute vacuum. For this measurement the measurement cell is sealed with full vacuum applied internally.

The output from an absolute sensor will change both as a result of any change in process pressure and any change in local barometric pressure. As a result, in order to determine actual process pressure / level from the sensors output a barometric reference value must be applied. This is usually provided by a separate input to the monitoring system from a sensor calibrated to measure barometric pressure.

Gauge sensors

In this case the measurement cell is vented to ambient air pressure through a vent tube in the sensors cable. This allows the outside ambient air pressure to be applied to the internal side of the cell to balance out ambient barometric pressure. Therefore, a vented gauge pressure sensor reads zero pressure when there is no process pressure applied.

Calibration of the sensors is undertaken at PSM using equipment with accuracy traceable to UKAS standards

3. Installation

3.1 Mechanical installation

Prior to installation it is recommended that the following checks are made:

- That the specific factory calibration is in accordance with the process parameters / tank height and that the APT 500 nominal range is suitable for the intended duty.
- Verify any instrument identification or tag number to ensure it is fitted in the correct location.

The cable is factory fitted to the APT 500 ensure a pressure tight seal. and no attempt should be made to remove the cable gland.

Instrument handling

Before and during installation the following precautions should be taken

- Do not touch the measurement cell of the APT 500 level transmitter or attempt to “simulate” a pressure being applied by manipulating the diaphragm. The diaphragm is highly sensitive and has a protective guard permanently attached.
- Do not apply mains voltage to any cable conductor.
- Ensure the APT cable is free from damage and defects.



Sensor cable

The cable that is factory fitted to the transmitter is purpose designed for the application. It contains a nylon vent tube which provides an atmospheric reference for the sensor if constructed for a “gauge” measurement application. The end of the nylon tube has a short section of silicon tube fitted, which carries a sintered filter. This filter provides a pressure path, but prevents any moisture entering the vent tube and **MUST** remain in place. If the cable is shortened this filter must be transferred to the new cable end.

Note that the cable has 4 cores. The Red and Black cores are used but the White and Green cores are not required and if the cable is shortened then these must be cut back and insulated.

Note that if the APT 500 is constructed as an “absolute” measuring device, then there is no requirement to vent the instrument cable to atmosphere. Precautions must still be taken however to prevent moisture ingress into the cable vent tube.

The cable construction is of sufficient strength to enable the sensor to be directly suspended in deep wells and reservoirs. The outer sheathing is a special material suitable for continuous immersion in water, and many oils and chemicals. When handling the cable take particular care not to damage the outer sheathing, and when securing using cable ties ensure that no sharp edges can cut the outer insulation or that the cable might be exposed to chafing by moving parts or vibration.

Ensure the cable is not bent to a radius less than 50mm.

When mounting the sensor allow sufficient free cable at the transmitter end to allow easy removal for testing without straining the gland in the transmitter body.

Sensor fitting height

When a transmitter is used in tank level or volume applications it is essential to ensure that the sensor is fitted at a known position and height above the bottom of the tank.

This data must be accurately recorded in the form of X, Y, Z coordinates referenced to known datums on the vessel e.g. baseline, keel or frame numbers.

All calibration data, and any trim or heel tank level measurement correction in the monitoring equipment will be related to this fitting position. If the sensor position is not accurately identified and in agreement with the correction factors the displayed values will be incorrect.

Mounting

When mounting the unit, and depending upon the type of mounting, ensure that suitable gaskets or sealants are employed to provide pressure tight seals. The sensor should not be mounted where it will be subject to excessive or continuous vibration, extreme temperature fluctuation or risk of mechanical damage.

Secure the cable as required over longer runs to prevent movement and mechanical abrasion. Do not secure the cable to sources of high temperature, e.g. steam coils used in HFO tanks.

Mounting Options

The APT 500 has an 1/2" BSPP process connection with a Viton sealing ring. PSM can provide a number of components and adapters for alternative mounting of the APT 500. Please contact for further details.

Where the sensor is not to be mounted via the front threaded process connection, i.e. where pole mounted or clamped in the tank, it will be supplied with a protective nosecone. This nosecone is cross drilled to allow free movement of liquid and must remain in place when the instrument is in service to protect the measurement diaphragm.

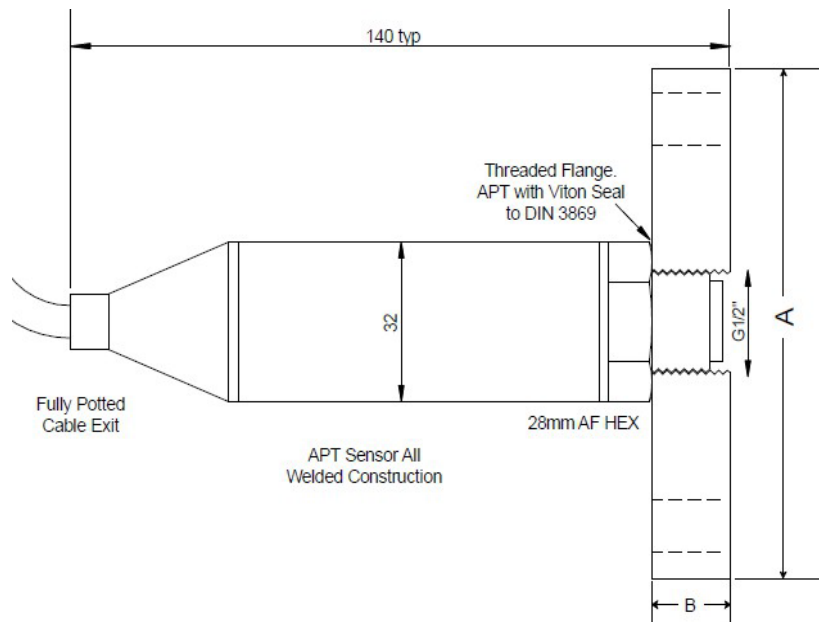

Model	Flange	Holes	PCD	Bolt Size	A	B
---	DN20 PN16	4	75	M12	105	18
---	DN25 PN16	4	85	M12	115	18
---	DN40 PN16	4	110	M16	150	18
---	DN50 PN16	4	125	M16	165	18

Note A minimum flange thickness of 18mm to prevent the sensor diaphragm from protruding past the face. The sensor should be tightened to 30 N-m and a Loctite 577 thread sealant, or equivalent, used.

3.2 Electrical installation

The APT 500 is 2 wire 4-20mA output transmitter.

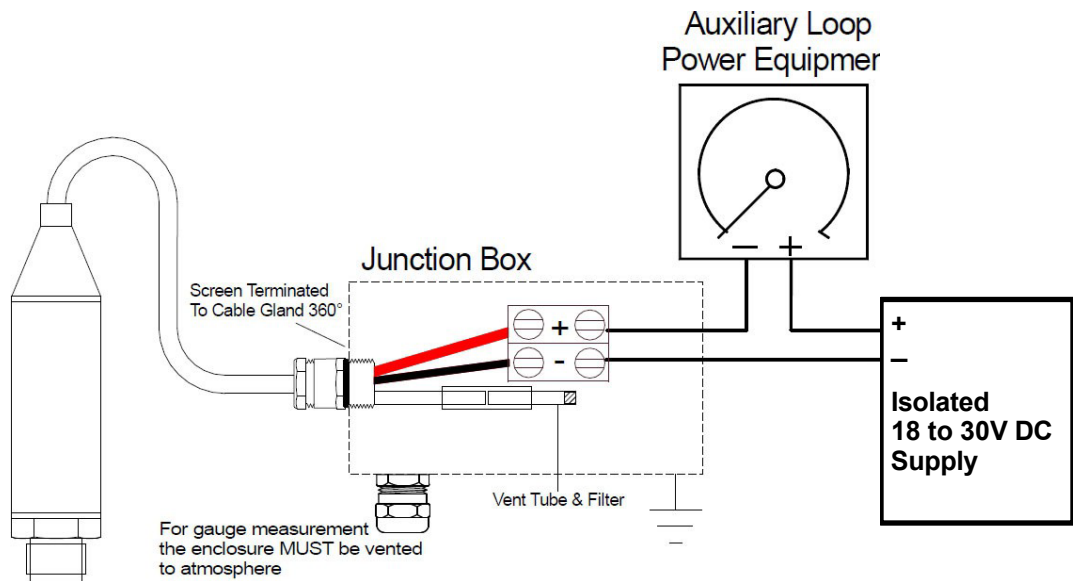

Connect Red conductor to +ve supply
Connect Black conductor to -ve supply.

The cable is also provided with an overall braided screen. Where the termination enclosure is metal and grounded this braid should be terminated in the cable entry gland ensuring that once installed it is connected to ground via the gland / enclosure. Where the enclosure is non-conductive, the third conductor which is a drain wire connected to the cable screen **must** be terminated to an appropriate earth terminal. This conductor and the overall braid are connected internally to the APT 500 sensor body, and to the internal electronics via a surge protection component (varistor). Connection of the cable screen to earth provides protection to the sensor against induced voltage spikes.

The APT 500 may also be provided with ATEX or IECEx certification suitable for hazardous area installation. For such applications additional safety components are required to limit the amount of energy that can be transmitted from the safe to hazardous side.

Refer to the applicable sections in **4.1**.

Isolated power supplies

For all installations of the APT 500 it is important that the instrument is powered from an isolated power supply. The use of a non-isolated power source could lead to issues with any onboard earth fault monitoring system, unwanted earth current loops and the possibility of instability / interference caused by any other equipment on the same power supply.

Electromagnetic Compatibility

To maintain compliance to the EMC standards the following should be observed:

- The overall braid should be terminated in the entry gland.
- The termination enclosure material to be metal or conductive RFI screened.
- All input/output cables from the termination enclosure to have overall braided screen terminated to entry gland.
- All cable screens should be terminated to the appropriate cable glands.
- All termination enclosures should be bonded to earth using an independent earth bonding strap. This strap should consist of either:
 - 2 x Copper conductors each minimum csa 1.5mm²;
 - 1 x Copper conductor minimum csa 4mm².

Fig 1

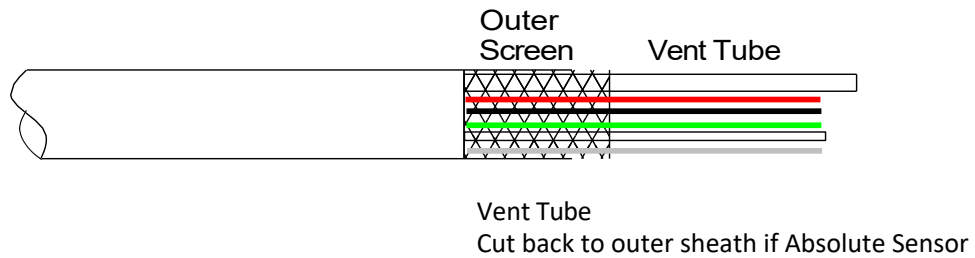

Fig 2

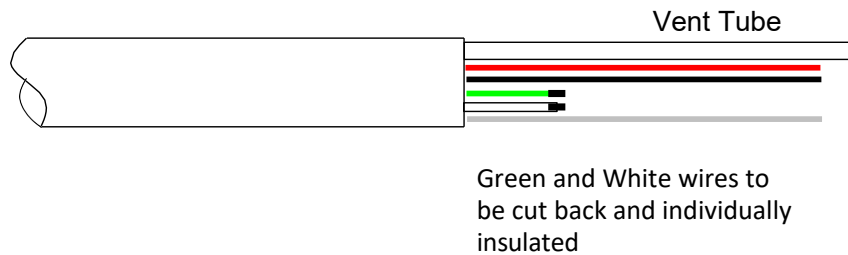
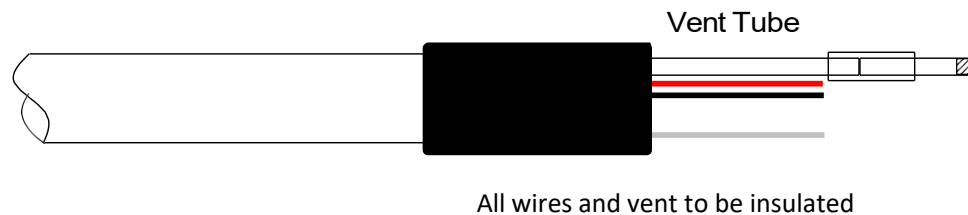

Fig 3



Red	+ Power	Analogue (4-20 mA)
Black	- Power	
Screen / Drain	Earth Connection	

Cable is normally provided to the required length with the ends terminated as depicted above.

If the cable needs to be shortened, the white and green cores must be individually insulated and then overall insulated with heatshrink tubing. Alternatively, they may be connected to unused terminals within the terminal box. **They must not be left loose and unterminated.**

If the cable has to be shortened, the nylon vent tube should be cut to a free length of approximately 20mm within the enclosure, it must be ensured that this tube is not blocked or otherwise restricted and the silicon tube containing the sintered filter **MUST** be re-fitted to the shortened length.

Where the sensor is measuring Gauge pressure the termination enclosure **MUST** be vented to atmospheric pressure.

If the termination enclosure is in a location which is not at atmospheric pressure then errors will result as the sensor will not be compensated correctly. In such cases a vent tube must be run from the termination enclosure to an area which is at true atmospheric pressure.

Care must be taken to ensure that any vent tube installed does not permit moisture ingress into the termination enclosure.

4. Supplement

4.1 ATEX and IECEx requirements

For intrinsically safe installations the APT 500 units in the hazardous area must be connected to the safe area via approved safety barriers. These barriers fall broadly into two categories:

- Zener barriers (based on the shunt diode principle)
- Galvanic isolators

Either type of barrier may be employed subject to it meeting the required safety description. PSM can provide guidance on a range of suitable barriers.

Shunt diode Zener barriers provide a resistor to limit the current flow, a (non-replaceable) fuse to limit power and a Zener diode arrangement to limit voltage levels and provide a safe path to earth. Zener barriers tie the 0v side of the transmitter supply to earth either directly or via a diode arrangement. They must be connected to a high integrity earth to function as intended.

Intrinsically Safe Earth Connections are required to be made but should be made to a separate instrumentation 'Clean Earth'.

There are generally two earthing systems recognised. The so-called 'dirty earth' has all the non-critical data equipment and general equipment attached to it. The 'clean earth' has all the critical data systems attached to it on the basis that less 'noise' will be found on this earth.

Galvanic Isolators provide full galvanic isolation between safe area and hazardous area circuits with power limiting achieved by using a diode resistor network similar to that of a shunt-diode barrier. They do not require a high integrity earth, each side may be earthed independently overcoming potential issues with earth loops.

For all intrinsically safe installations of the APT 500 it is essential that this instrument is powered from an isolated power supply. When a zener barrier is employed for power limiting this will effectively tie the sensor supply 0V to earth, meaning a non-isolated power source can lead to issues with any onboard earth fault monitoring system, resulting in unwanted earth current loops and instability / interference caused by any other equipment on the same power supply.

The use of an isolated supply means that there is no direct connection between the 0 volts / I.S. earth at the sensor and the 0 volts at the ships supply.

APT 500/I ATEX Approval

The optional intrinsically safe version of the APT 500/I is covered by the following certification for use in hazardous areas.

Approval Certification

- ITS18ATEX203153X



Ex ia IIC T4 (T amb -30°C to +85°C)

ia Intrinsic Safety
IIC Acetylene & Hydrogen (Presence of Flammable/Combustible gas)
T4 135°C (Maximum Surface Temperature)

Barrier selection

When selecting a Barrier the following parameters must be complied with:

U_i = 28Vdc
I_i = 93mA
P_i = 0.7W
L_i = 0
C_i = 12nF

Conditions of Certification

Non-metallic parts on the exterior of the pressure transmitter may present an electrostatic charging hazard.

Warning – Potential electrostatic charging hazard. Clean only using a damp cloth.

Where external parts of the pressure transmitter incorporate light metal components (i.e. in excess of 10 % in total of aluminium, magnesium, titanium and zirconium), the sensor must be protected from impact such that impact / friction sparks cannot occur, taking into account rare malfunction.

Installation requirements

The following standard should be followed when carrying out a hazardous area installation:
60079 Part 14.

Strictly no modifications or user repairs are allowed.

If any problems occur with the equipment, please contact PSM Instrumentation.

APT 500/X IECEx Approval

The optional intrinsically safe version of the APT 500/X is covered by the following certification for use in hazardous areas.

Approval Certification

- IECEx ITS 18.0012X

Ex ia IIC T4 (T amb –30°C to +85°C)

ia Intrinsic Safety

IIC Acetylene & Hydrogen (Presence of Flammable/Combustible gas)

T4 135°C (Maximum Surface Temperature)

Barrier selection

When selecting a Barrier the following parameters must be complied with:

U_i = 28Vdc
I_i = 93mA
P_i = 0.7W
L_i = 0
C_i = 12nF

Conditions of Certification

Non-metallic parts on the exterior of the pressure transmitter may present an electrostatic charging hazard.

Warning – Potential electrostatic charging hazard. Clean only using a damp cloth.

Where external parts of the pressure transmitter incorporate light metal components (i.e. in excess of 10 % in total of aluminium, magnesium, titanium and zirconium), the sensor must be protected from impact such that impact / friction sparks cannot occur, taking into account rare malfunction.

Installation requirements

The following standard should be followed when carrying out a hazardous area installation:

60079 Part 14

Strictly no modifications or user repairs are allowed.

If any problems occur with the equipment, please contact PSM Instrumentation.

4.2 Technical Data

Specifications		
Materials	Sensor body	316L Stainless Steel or Titanium. Hastelloy C276 option for Wetted parts for external (to tank) mounting.
	Diaphragm	316L or Titanium to match body material. Hastelloy C276 process ports use Tantalum diaphragm.
Standard Measurement Ranges (Bar)	0.2, 0.5, 1.0, 2.5, 4.0, 10, 25, 40. (Other ranges to special order)	
Measurement type	Vented Gauge or Absolute – refer to PSM for availability of ranges	
Overload	2 x Nominal range with no effect	
Span setting accuracy	0.2% within compensated range	
Zero setting accuracy	0.2% within compensated range	
Total Error Band	+/- 0.2% of Nominal range at reference conditions of 25°C	
Thermal effect	Max +/- 0.0075% of Nominal range for Zero & Span /°C from reference	
Long term stability	Error not exceeding +/- 0.1% Per Annum	
Max / Min process temperature	-30 to +85°C	
IP Rating	IP68 suitable for continuous immersion	
IECEX certification	IECEX ITS180012X.0 Ex ia IIC T4 Ga -30°C ≤ Ta ≤ +85°C	
ATEX certification	ITS18ATEX203153X Issue 0 Ex ia IIC T4 Ga -30°C ≤ Ta ≤ +85°C	
Signal Output / Power supply	4-20mA / 18 to 30V DC (2 wire)	
Reverse Polarity Protection	Yes	
Maximum load	Supply dependant. $V_s - 18/0.02 = \text{Load in Ohms}$	
Weight	0.3Kg typical for body. Cable 0.1Kg / metre	

APT500 Series Level Transmitter							
550S	APT 550 4-20mA 2 Wire Transmitter - Submersible construction with cable						
Certification							
S	Hazardous Area Approval NOT APPLICABLE						
I	Certified Intrinsically Safe to ATEX - Hazardous Area Approved						
X	Certified Intrinsically Safe to IECEx - Hazardous Area Approved						
IX	Dual Certification ATEX / IECEx - Hazardous Area Approved						
Measurement Type							
A	Absolute						
G	Gauge						
Nominal Range							
Absolute			Nominal Range			Gauge	
	TI	SS	HT		TI	SS	HT
A	N/A	N/A	N/A	A	N/A	0.2 Bar	N/A
B	N/A	N/A	N/A	B	0.5 Bar	0.5 Bar	0.5 Bar
C	N/A	N/A	N/A	C	1.0 Bar	1.0 Bar	1.0 Bar
D	2.5 Bar	2.5 Bar	2.5 Bar	D	2.5 Bar	2.5 Bar	2.5 Bar
E	4.0 Bar	4.0 Bar	4.0 Bar	E	4.0 Bar	4.0 Bar	4.0 Bar
F	10 Bar	10 Bar	10 Bar	F	10 Bar	10 Bar	10 Bar
H	25 Bar	25 Bar	25 Bar	H	25 Bar	25 Bar	25 Bar
I	40 Bar	40 Bar	40 Bar	I	40 Bar	40 Bar	40 Bar
J	60 Bar	60 Bar	60 Bar	J	60 Bar	60 Bar	60 Bar
Process Connections & Fitting Options (options marked ** are not available for TI versions)							
1	1/2" BSP Male (Standard connection). Material is as specified for the main body						
3	G1" Male Adapter in 316 Stainless Steel						
6	G1/2" to DIN EN837 in Stainless Steel (Special order, refer for delivery time)						
7	Pole Adapter Threaded G 1/2" Female Adapter in 316 Stainless Steel**						
8	Pole Adapter Threaded G 3/4" Female Adapter in 316 Stainless Steel**						
11	St. Steel Sensor with Drain wire adapter - Specify drain wire length in Metres						
14	Titanium Sensor with Drain wire adapter - Specify drain wire length in Metres						
15	1" ANSI 150 lb St. Steel Flange (Supplied loose)						
17	Stilling Pipe Flexible Stainless Steel Cage pipe Installation. Suitable for Stilling Pipe I.D. of 2" to 3" (applicable for all sensor materials).						
18	Pole Adapter Threaded G1/2" Female- Replacement for ICT transmitter						
22	G1/2" male with Flexible Protection Compound - no Diaphragm Guard						
23	Pole Adaptor Threaded G1/2" Male						
Cable Length mtrs (only applicable to APT 1000 versions)							
**	Heavy Duty Vented Cable - 3 Metres included as standard						
Q**	As above but cable outer jacket PTFE coated (Subject to Availability)						
R**	As above but cable outer jacket Flame Retardant (Subject to Availability)						
S**	As above but cable outer jacket FEP Coated (Subject to Availability)						
Z**	Custom cable (refer to discuss requirements)						
Transmitter Body Material							
TI	Titanium (Body & Diaphragm)						
SS	Stainless Steel (Body & Diaphragm)						
HT	Hastelloy / Tantalum wetted parts (St. Stl. Body)						
Transmitter Orientation							
H	Horizontal						
V	Vertical - Diaphragm facing down						
U	Vertical - Diaphragm facing up						

Example: 550S S A E 1 3 TI H

Written as: 550S/SA/E/1/3/TI/H

Note: Transmitter will be calibrated for 4-20 mA over Nominal range as standard. Where a specific calibration range is required this must be advised separately.

Actual calibration can be a maximum of 2:1 turndown from Nominal range.

Optional Extra	
APT Internal Fixing Clamp Assembly	Supplied Loose
Process Connection DN20 PN16 SS Flange with G1/2" Female Threaded Centre	Supplied Loose
Process Connection DN25 PN16 SS Flange with G1/2" Female Threaded Centre	Supplied Loose
Process Connection DN40 PN16 SS Flange with G1/2" Female Threaded Centre	Supplied Loose
Process Connection DN50 PN16 SS Flange with G1/2" Female Threaded Centre	Supplied Loose
Process Connection 1" ANSI 150lb SS Flange with G1/2" Female Threaded Centre	Supplied Loose
Process Connection 2" ANSI 150lb SS Flange with G1/2" Female Threaded Centre	Supplied Loose
APT De-Mountable Pole Assembly with Top Flange (SS ONLY) - Flange Size to be Confirmed by Customer	Max Length 2000mm
Assembled Length From Underside of Top Flange to End of Sensor TBC	Assembly Supplied Loose

4.3 Dimensions—submersible version

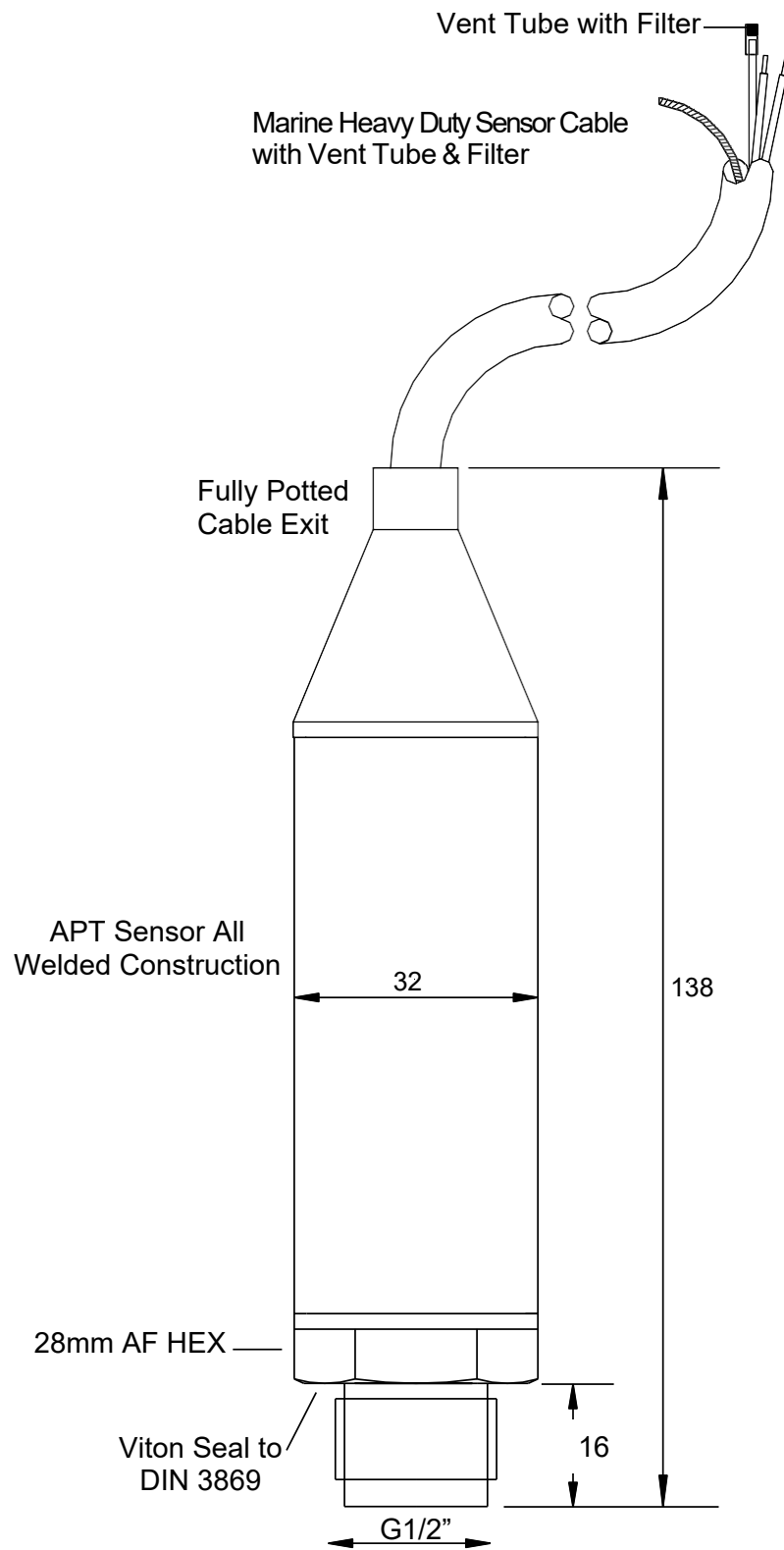

Consult PSM for fitting adapters and options

4.4 Dimensions—DIN terminal head version

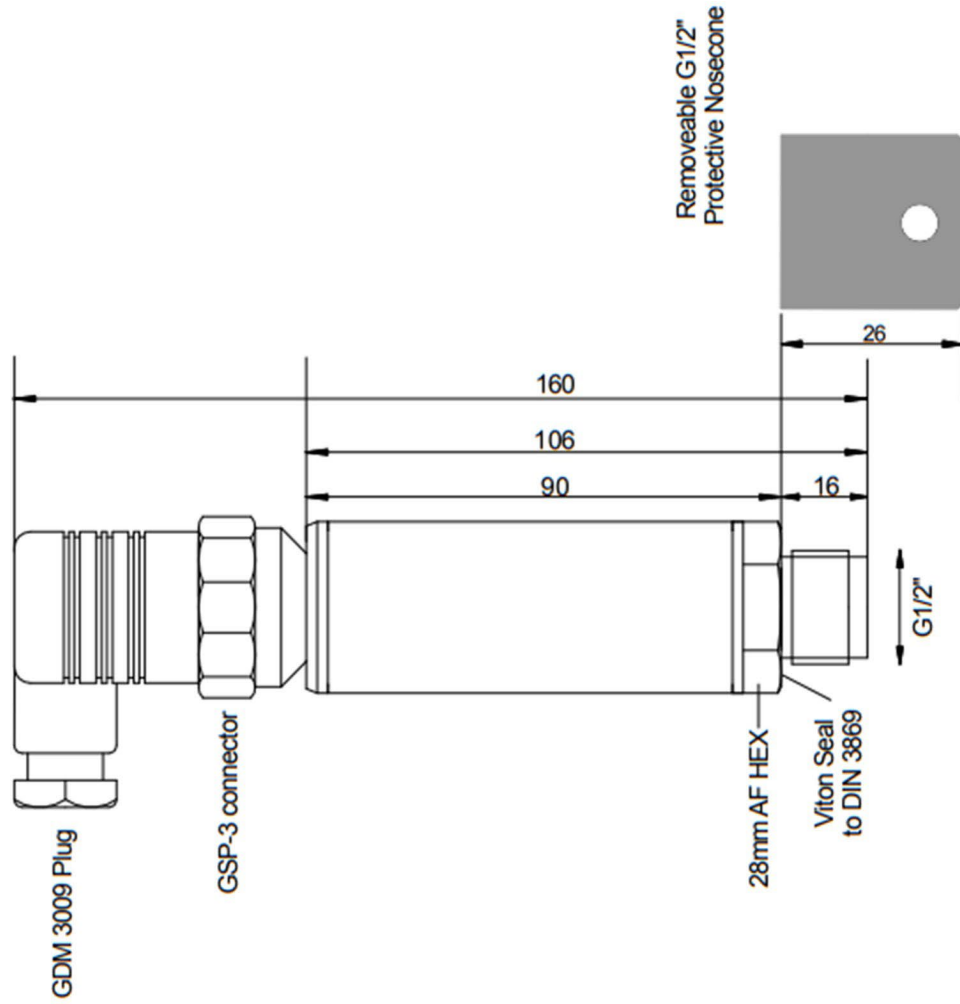

APT500 DIN PLUG IDENTS	
Terminal 1 + Positive	Supply
Terminal 2 - Negative	4-20mA
Terminal 3	Not Used
Terminal 4	Not Used
	RS485 Data

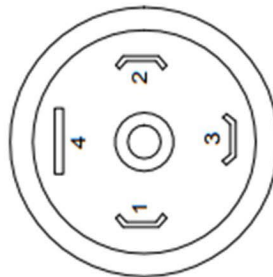

4.5 Dimensions—Stainless Steel terminal head version

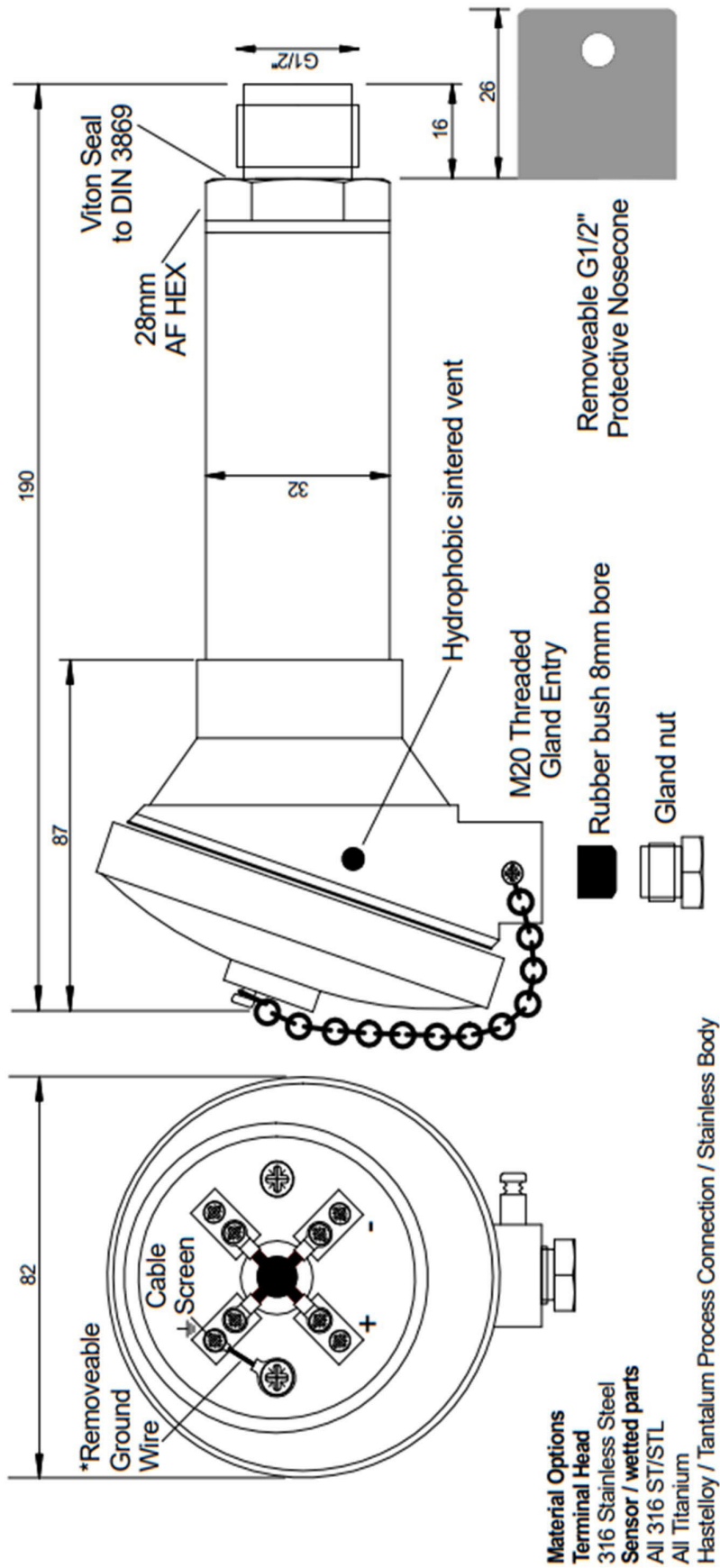

PSM WEEE Producer Registration No WEE/HC0106WW

Burrell Road Industrial Estate
Haywards Heath, West Sussex RH16 1TW, UK
Tel: +44 (0)1444 410040
www.psmmarine.com E-mail: sales@psmmarine.com