

SALES DRAWING ONLY  
NOT TO BE USED FOR MANUFACTURE

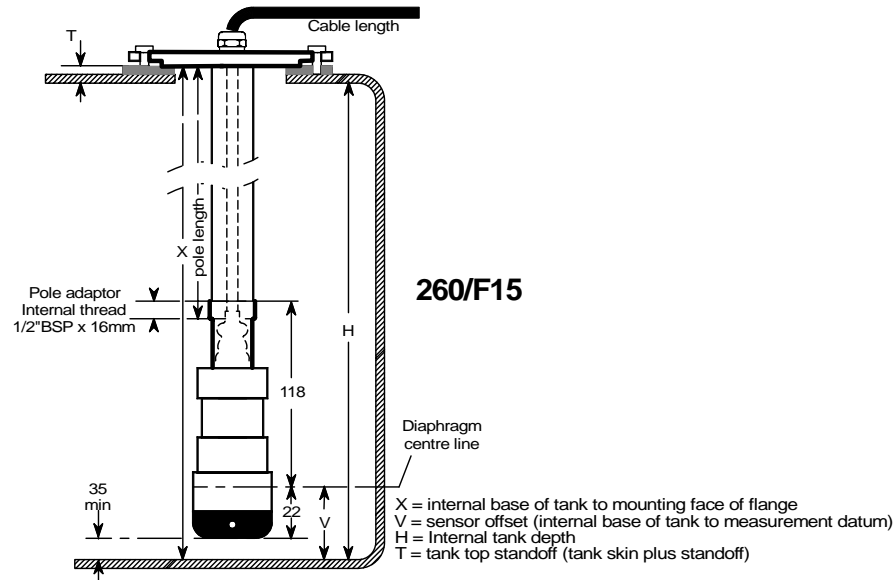

260/F15

X = internal base of tank to mounting face of flange  
V = sensor offset (internal base of tank to measurement datum)  
H = Internal tank depth  
T = tank top standoff (tank skin plus standoff)

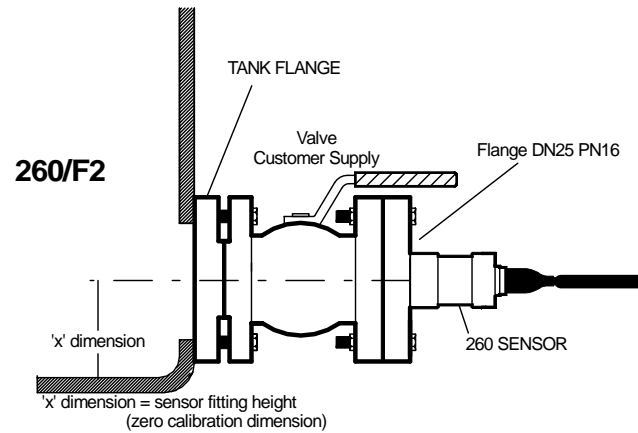

260/F2

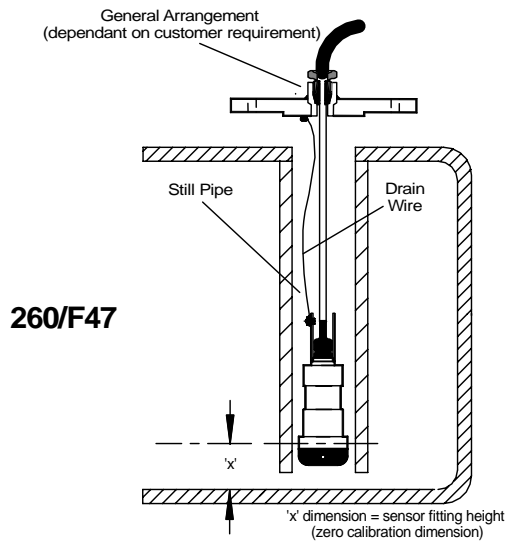

260/F47

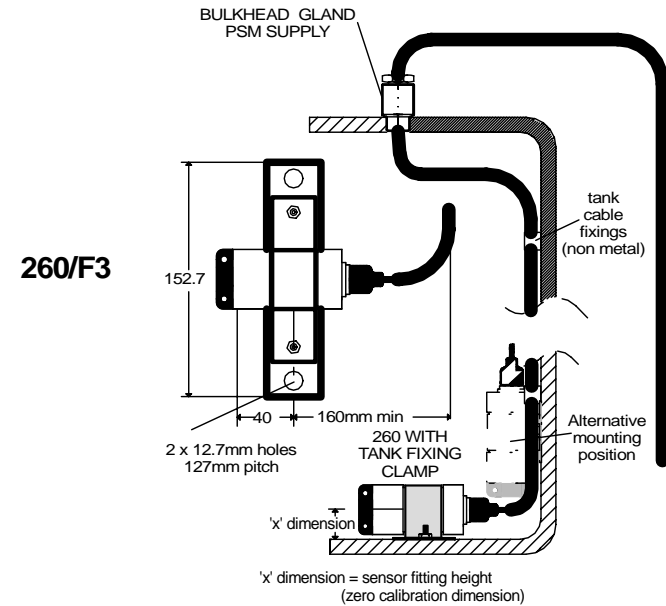

260/F3

**PSm** Instrumentation Ltd

Haywards Heath, West Sussex RH16 1TW  
ph: 44 (0) 1444 410040 f: 44 (0) 1444 410121  
<http://www.psm-sensors.co.uk>

SCALE  
NTS

UNLESS OTHERWISE STATED DIMENSIONS ARE IN  
MILLIMETRES / INCHES

TITLE  
General Sensor  
Installation

DRAWING NO  
S-001250-360-GO

A4 SHT 1 OF 1

ISSUE	B		
DATE	A	01-11-04	07-04-08
DDR			
DRAWN		JEK	JEC
CHECKED			