

SALES DRAWING ONLY  
NOT TO BE USED FOR MANUFACTURE

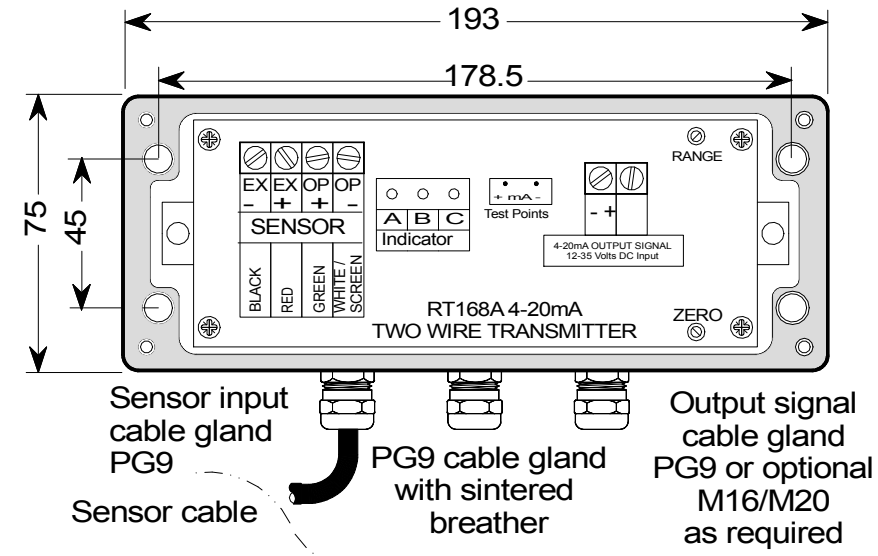
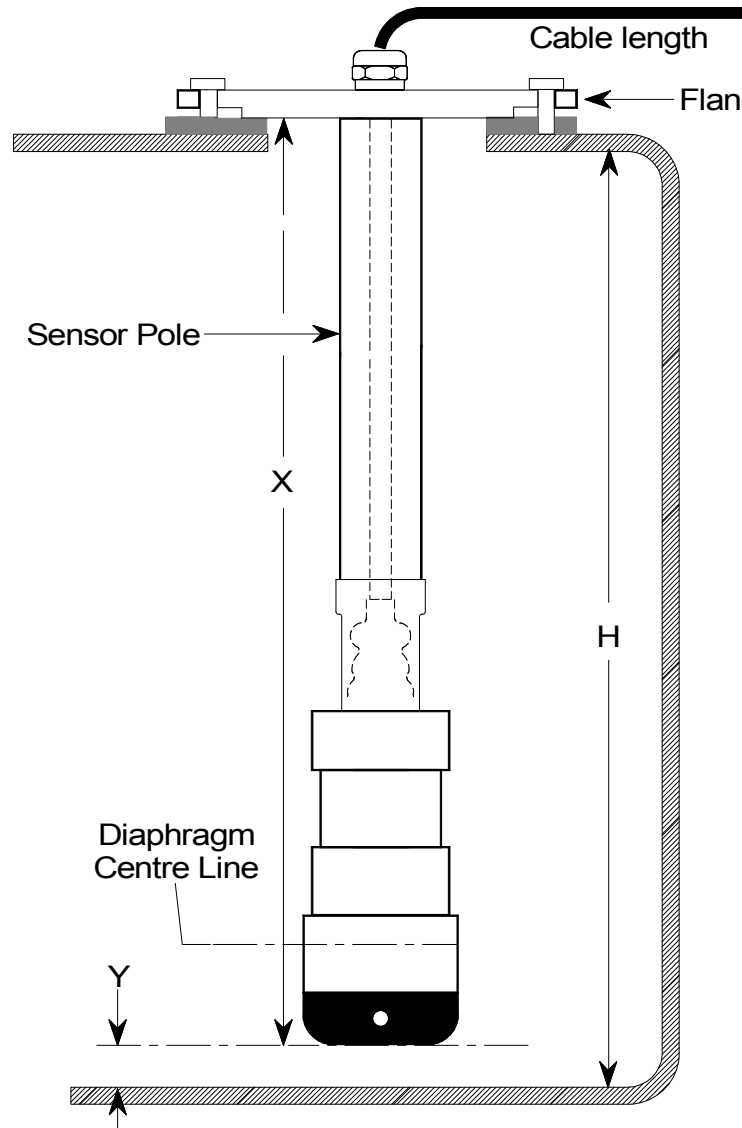

**To Determine Correct Pole Assembly Length & Calibration Confirm the Following:**

- H = Tank Height ??
- X = Pole Assembly Length From Underside of Flange to end of Sensor Taking into Account Any Standoff Height ??
- Y = Sensor Height From Bottom Tank to Sensor End ??
- Product SG Value ??

ISSUE	D	29-04-14	SAL
DATE	C	09-03-11	SAL
DCR	B	18-07-02	JEK
DRAWN	A	26-06-02	JEK
CHECKED			

**PSm** Instrumentation Ltd

Haywards Heath, West Sussex RH16 1TW  
 ph: 44 (0) 1444 410040 f: 44 (0) 1444 410121  
<http://www.psm-sensors.co.uk>

SCALE  
NTS

UNLESS OTHERWISE STATED DIMENSIONS ARE IN  
MILLIMETRES / INCHES

TITLE  
260/360 Level Transmitter  
Pole mounting

DRAWING NO  
S001173-260-DD

**A4** SHT 1 OF 1